

BET 14 | Private

The Private Classification units are the smallest units in our product line. These units are often used in country residential and light agricultural applications.

MODEL BET 14

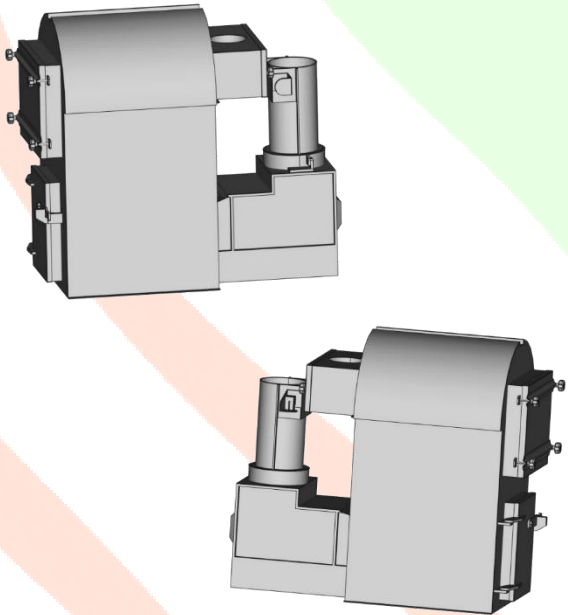

TECHNICAL SPECIFICATIONS:

BTU Output (btu/hr)	510,000
Thermal Energy (kWth)	149
Maximum Consumption (kg/hr)	49
Maximum Screening Size (cm)	4
Base Footprint Width (cm)	121
Base Footprint Length (cm)	254
Application Classification	Private
Operating Temperature (C)	1250°
Gas Retention (seconds)	~2

The BET Technology by BioMass Energy Techniques Inc is currently being used in over 100 applications across North America. This technology has proven versatile and effective on a wide range of feedstocks with high moisture content. Traditionally used to consume wood waste as a fuel feedstock, the basis of the BET system has been proven over many decades in both off-grid and newer leading edge technology applications.

OPTIONAL UPGRADES:

BioChar TakeOut Module with Airlocks	Stainless Steel Package
Touchscreen PLC Controls	Non-Electric Controls
Smart Phone Connectivity	Solar Island Power Source
Remote Monitoring (WiFi/Ethernet)	MicroGen Power Module



BIOMASS ENERGY

TECHNIQUES INC

Toll Free: 1 (888) 828-7637
www.biomassenergytechniques.com
The New Dimension In Renewable Energy